

The Potential of Distributed Generation to Provide Ancillary Services

G. J6os¹, B.T. Ooi², D. McGillis¹, F.D. Galiana² and R. Marceau³

¹Department of Electrical and Computer Engineering
Concordia University
Montreal, Quebec, Canada, H3G-1M8
Tel.: (514) 848-3080 Fax: (514) 848-2802
e-mail : geza@ece.concordia.ca

²McGill University, Canada

³Ecole Polytechnique de Montreal, Canada

Abstract. The growing concerns regarding electric power quality and availability have led to the installation of more and more distributed generation. In parallel and in the context of an accelerating trend towards deregulation of the electric industry, the unbundling of services, many grouped under ancillary services, should create a market for some of these services. This paper discusses the potential of distributed generation (DG) to provide some of these services. In particular, DG can serve locally as the equivalent of a spinning reserve and voltage support of the ac bus. The main types of distributed generation with emphasis on the power electronic interface and the configurations appropriate to provide ancillary services are reviewed. The flexibility and features provided by the power electronic interface are illustrated. In addition to control of the real power, other functions can be incorporated into the design of the interface to provide services, such as reactive power, and resources associated with power quality. These include voltage sag compensation and harmonic filtering. The implications on the design of the power converter interface are discussed.

Keywords: Distributed generation, Ancillary services, Power electronic interface, Deregulation

I. INTRODUCTION

An area of growing interest is distributed generation (DG), as it is seen as a means of satisfying the growing need in electric energy. DG is often lumped with distributed storage and the combination of the two is known as Distributed Resources. The interest in DG is the result of the opening of the energy markets under deregulation and of recent technological advances in electrical and mechanical power conversion systems. These include cheaper and more efficient static power converters, gas and wind turbines [1, 2, 3], and photovoltaic [1, 4, 5] and fuel cells. In order to be more effective, distributed generation which provides variable power, such as wind energy and photovoltaic energy, can be associated with energy storage, such as batteries.

Although a number of these systems employ electric generators that can be coupled directly to the electric grid, the trend is to use a power electronic interface. Power electronic converters employ line-commutated switching devices, such as thyristors, or more recently, self commutated devices, such as high power IGBTs, GTOs and IGCTs. These power electronic interfaces can be configured to provide some of the ancillary services. In addition to being available as power reserve, they can be designed to provide reactive power, load balancing, voltage support, and harmonic mitigation.

This paper presents the more common types of distributed generation and the associated power electronic interfaces that allow their use as ancillary service providers. The capabilities of the power electronic interfaces are presented, and the implications on the design of these interfaces are detailed.

II. BACKGROUND

A. Role of Distributed Generation

In addition to meeting future energy needs, it is expected that distributed generation (DG) will have increasing importance in a deregulated environment for a number of reasons:

- (a) It can provide independence and flexibility to the consumer in planning and developing the installation. This is particularly important for sensitive and critical loads in environments subjected to interruptions and curtailments.
- (b) The cost of energy produced by DG is decreasing to the point where it becomes competitive with grid supplied electric energy. Power companies can therefore add generation at critical points in the power grid, in particular near loads. This can result in significant savings in the electric distribution infrastructure, particularly expansions.
- (c) It allows for independent production of electric energy by a consumer, possibly at a cheaper rate, thus saving on the utility bill. Excess energy can be posted on the spot market and made to generate a profit.
- (d) With decreasing costs, independent power producers (IPP) can install generation and connect to the power grid, to sell energy at a profit.
- (e) It has the potential of providing some of the ancillary

services that have been identified as a result of deregulation. The IPP as well as consumers having independent generation could provide these services.

B. Ancillary Services

Ancillary services are defined as services provided in addition to real power generation by the electric utilities under a monopoly, and services that must be provided separately under a deregulated environment (Table 1, based on the Federal Energy Regulatory Commission, FERC, requirements). These include:

- (a) Reactive supply (absorption and injection) to achieve voltage control.
- (b) Regulation, load power consumption tracking: functions typically performed by automatic generation control (AGC).
- (c) Operating and spinning reserves: provision for generating capacity following generation outages, planned and forced respectively.
- (d) Energy imbalance: the use of generation to correct mismatches, and frequency control; load following: the use of generation to meet load variations.
- (e) Network stability services: power system stabilizer and dynamic braking functions.

It should be noted that reactive power supply and voltage control at the transmission level are the responsibility of the transmission provider or Independent System Operator (ISO). The question of marketability of these services is still under discussion, and in some cases, it is unclear whether providing these services can generate a profit. To have an impact in this area, DG would have to be aggregated.

In addition, deregulation may have a significant impact on electric power quality. Electric energy may be made available at different quality levels, with high quality associated with higher costs. This may require special devices.

Distributed generation may have both a positive and a negative impact on power quality. This will depend upon the type and amount of distributed generation, as well as the power interfaces and control schemes used to connect these units to the grid. These issues are addressed in this paper.

C. Types of Distributed Generation

Distributed generation includes mostly electric energy provided by alternate sources of energy, beyond the conventional sources such as hydro-electric, coal, oil, and nuclear. Because of its limited power, it can most easily be connected to the ac grid at the distribution level, typically 25 kV. Among the more common and cost effective, Table 1, are:

- (a) Wind energy systems: the resource is abundant and these systems are gaining popularity. Power ratings are steadily increasing.
- (b) Photovoltaic cells: although less powerful than wind energy systems, they offer more flexibility and are passive.

- (c) Microturbines: a number of these systems derive from systems developed for the military.
- (d) Fuel cells: although the principle has been known for many years, these systems have recently received a large amount of attention as a less polluting replacement for crude oil derived generating systems.
- (e) Solar dishes: since these generate heat, they may be combined with non solar fuels, such as natural gas, resulting in hybrid systems that can be cost effective and supply continuous power.
- (f) Other types include gas turbines, diesel engines and gas fired internal combustion engines.

Table 1. Partial list of ancillary services required in a deregulated environment (based on FERC).

Service	Time Scale
<i>Services the transmission provider or Independent System Operator (ISO) must offer</i>	
Reactive supply and voltage control, generation level	Seconds
<i>Services customers can take from the transmission provider, buy from third parties, or self-provide</i>	
Regulation, gen./load balance	1 min
Operating reserve - spinning	Seconds to 10 min
Energy imbalance	Hourly
<i>Services transmission providers do not have to offer but that the ISP supplies</i>	
Load following	Hours
Real power losses	Hourly
Dynamic scheduling	Seconds
Network stability	Cycles

III. DISTRIBUTED GENERATION

Some of the distributed generation systems that hold the greatest technical potential, Table 2, are described with reference to the types of power electronic interfaces and their characteristics.

A. Microturbines

A typical scheme is shown in Fig. 1. Because the turbines run at high speeds, up to 80,000 rpm, the ac generator is a high frequency generator that cannot be coupled directly to the ac grid. An intermediate dc link is used, a dc capacitor fed from the diode rectifier. A dc/ac inverter produces voltages at the power system frequency. It is of the voltage source type, and is currently using IGBTs up to the MW range.

Table 2. Principal types of distributed generation systems.

Type	Power range
Microturbines	25 kW – 1 MW
Wind energy systems	100 kW – 2 MW
Photovoltaic	5 kW – 100 kW
Fuel cells	100 kW – 2 MW

B. Wind turbines

The wind turbine can be operated at either constant or variable speed and coupled to either a synchronous or induction generator producing power system frequencies. The latter has been widely used due to simplicity and lower cost. The variable speed turbine has a simpler mechanical system and is the preferred solution in newer installations. Fig. 2 (a) shows an induction generator system. An alternative method of operating the induction generator is by means of the Scherbius drive scheme. These systems were implemented in the past as slip energy recovery systems based on a diode rectifier fed a dc current link into a thyristor inverter connected to the ac grid. The line commutated converters are being replaced with self commutated, typically IGBT based, converters, Fig. 2 (b) [3]. The rotor is fed at a frequency such that the sum of the mechanical and the rotor slip frequencies is equal to the ac grid frequency. The power rating of the converters depends upon the speed range selected. The converter system can reverse power which allows operation of the induction generator above rated synchronous speed.

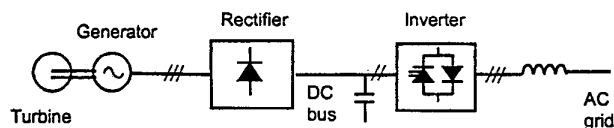

Fig. 1. Microturbine electrical system.

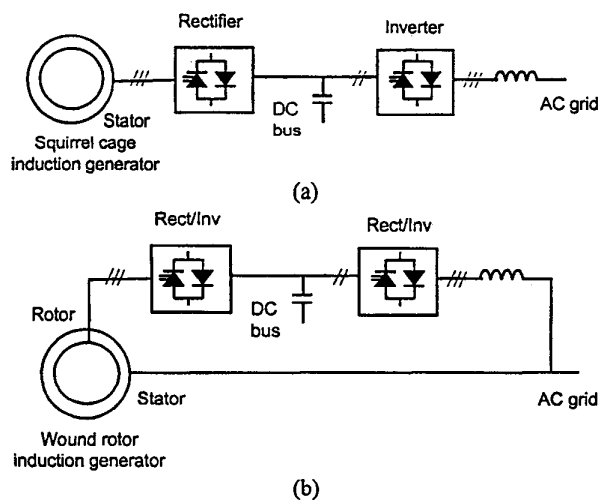

Fig. 2. Wind turbine electrical system. (a) Variable speed induction generator. (b) Doubly fed variable speed induction generator.

C. Photovoltaic systems

A common scheme involves the use of a dc/ac inverter, converting dc energy produced by the cell into ac voltage synchronized with the grid, Fig. 3 [5]. The control system is designed to track peak power points. The three-phase inverter is typically of the IGBT type.

D. Fuel cells

The dc voltage produced by the cell is converted into ac using a dc/ac inverter similar to that of a photovoltaic system.

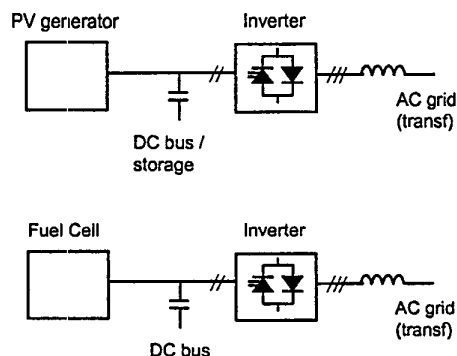

Fig. 3. Photovoltaic and fuel cell electrical conversion systems.

IV. POWER ELECTRONIC INTERFACE FEATURES AND CAPABILITIES

The schemes presented above all have one element in common: the interface to the ac distribution grid (typically up to 25 kV) uses a self commutated Pulse Width Modulation (PWM) dc/ac inverter. This interface allows the generation scheme to be configured for a number of functions as described below. Some of these functions have been previously implemented on ac synchronous generators through the excitation system, namely for reactive power control, power system stabilization and power system damping. It should be noted that a number of these functions cannot be implemented using the more conventional power interface scheme: for example, induction generators and thyristor converters do not allow control of the reactive power, since they draw an amount of reactive that is related to the operating conditions.

A. Self commutated converter systems

Converters are basically of 2 types:

- Line commutated, based on thyristors.
- Self commutated, using fully controllable switches such as the IGBT (typically for low voltage, low and medium power applications) or the GTO or IGCT (for medium voltage and medium and high power applications). Advantages are described below.

In addition, the dc bus can be either of the:

- Current source type, that is inductive. Thyristor converters are of the current source type.
- Voltage source type, that is capacitive, Fig. 4.

Self commutated converters can be of either type. However, at this time, voltage source converters are the preferred topology, Fig. 4. This is the result of switch technology, which favors switches with a reverse conducting diode, the cost, weight and size, which favor capacitors over

inductors, and the presence of a voltage bus. The voltage bus allows the connection of energy storage such as batteries.

Control options include:

- (a) Direct inverter voltage control. Angle and magnitude of this voltage dictate the real and reactive power transfer, Fig. 5 (d).
- (b) Inner current loop, Fig. 6. Advantages of this option are the direct control of current angle and power factor, Fig. 5 (b), inherent current limit, and the possibility of injecting balanced ac currents into the power system. This last feature may be desirable when the system voltages are unbalanced. Current control requires PWM control at switching frequencies above 1 kHz.

In recent years, and partly as a consequence of the extensive developments in ac motor drives, the dc/ac three-phase bridge inverter has become a standard in many applications. The converter, of the voltage source type, fed from a capacitive dc bus, uses IGBT devices with an anti-parallel diode (usually the built-in body diode), Fig. 4. These converters are known as 2 level, three-phase converters. Units up to 1 MW or more are available in the low voltage range (typically 600 V). Recently converters have appeared for direct coupling to medium range voltages (up to 6.6 kV) and are of the 3 level type.

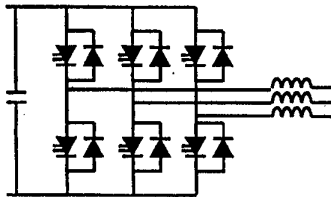

Fig. 4. PWM self commutated inverter power circuit, voltage source configuration (the coupling transformer provides the line side reactance X).

The converter usually switches up to a few kHz or more, depending upon the application. This results in a number of improved features over line commutated converters:

- (a) The inverter voltage harmonic components are large but at a high frequency. The ac line current harmonic components are therefore small.
- (b) The dynamic response of the inverter is fast since the delay in changing inverter operation is on average of the order of half a switching period.

The same inverter can be used as a rectifier, that is, convert ac into dc. The combination of rectifier and inverter allows the implementation of frequency changers, with independent control of voltage and frequency on the both ac sides, Fig. 3. The dc bus allows this complete decoupling. In addition, energy storage (batteries) can be connected to the dc bus. The dc bus provides flexibility to the structure and it can be used in a number of ways:

- (a) A number of rectifiers can be connected to a common dc bus. The dc voltage is converted into ac by a single dc to ac inverter, connected to the ac grid. This allows transmission

of power in dc rather than ac form, which has a number of advantages. In particular, no reactive power is required to transmit power. This means that no reactive power compensation is required even for long distance lines. A common dc bus also allows a mix of generation to be combined, for example diesel driven generators, wind energy systems and photovoltaic systems. Energy from all of these sources is converted into ac by one or more dc/ac inverters, connected to one or more ac grids (multi-terminal high voltage dc HVDC transmission) or to independent loads.

- (b) If the dc bus is controlled from the ac grid side, the inverter can provide reactive power, even in the absence of real power on the dc bus. Wind energy systems can operate as var compensators in the absence of wind.

B. Power flow control – real and reactive components

The converter can be considered as a static synchronous ac source, coupled to the ac grid through a reactor, in many cases provided by the coupling transformer. Since the converter is self commutated, it can produce an ac voltage of an arbitrary amplitude and phase, Fig. 5 (b). In a manner similar to synchronous generators, Fig. 5 (c), there are two control variables:

- (a) The position of the fundamental component of the inverter output voltage V_{c1} relative to the ac grid voltage V_L , defined by the load angle δ , Fig. 5 (d). The power transferred from the inverter to the ac grid, on a per phase basis, is given by:

$$P = \frac{V_L V_{c1}}{X} \sin \delta = V_L I_{L1} \cos \phi \quad (1)$$

- (b) The amplitude of the inverter output voltage V_{c1} , controlled by the modulation index of the PWM pattern generator. This amplitude directly controls the amount of reactive power drawn or injected into the ac grid:

$$Q = \frac{V_L (-V_L + V_{c1} \cos \delta)}{X} = V_L I_{L1} \sin \phi \quad (2)$$

where X is the coupling reactance between the inverter and the ac grid. The reactive power depends upon the angle between the line current fundamental component I_{L1} and the grid voltage V_L .

The inverter can therefore be operated at any desired power factor, including unity power factor. This is in contrast to line commutated converters that always operate at a lagging power factor. In typical applications, the power factor may be 0.8, corresponding to a reactive power of 0.6 pu. This reactive power is usually supplied by the ac grid, or in large installation, by power factor correction capacitors. Self commutated converters therefore have a lower kVA converter rating.

However, it may be desirable to operate the DG system so it supplies reactive power to the grid. In the current mode, this is achieved by adding a reactive current, i_q , component to the reference inverter current i_d defining the real power transfer,

Fig. 6. The d and q axis currents can be controlled independently.

Supplying reactive power however significantly increases the converter kVA rating. If a reactive power of 0.6 pu is supplied in addition to the 1.0 pu real power, the converter rating increases by 17 % to 1.17 pu. For 1.0 pu reactive power, this figure increases to 1.4 pu.

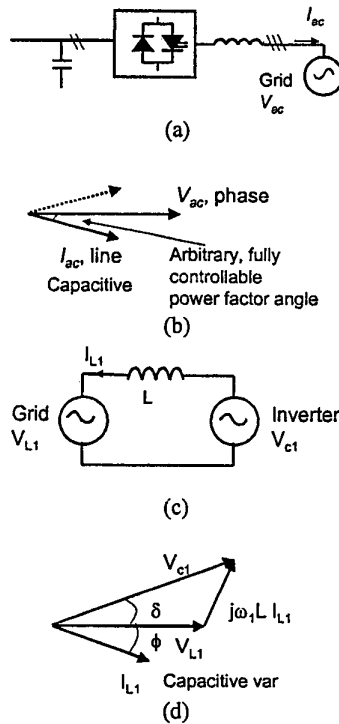

Fig. 5. PWM inverter power control (reactor may be the transformer leakage reactance). (a) Simplified representation. (b) Voltage-current relation. (c) Per phase equivalent circuit at fundamental frequency ($V_{L1} = V_L$, $j\omega L = X$). (d) Phasor diagram at the fundamental frequency (inverter supplies vars).

C. Power quality issues

Distributed generators equipped with rotating converters, either induction or synchronous generators, produce sinusoidal voltages, assuming the machine harmonics have been taken care of (distortion induced 3rd harmonic and slot harmonics, typically 18th or higher). However, static power converters may inject significant harmonic currents into the ac system. This is the case for the following:

- (a) Thyristor converters, which can be viewed as current sources. Six pulse converters typically inject odd harmonics of order 5, 7, 11, 13, ...
- (b) Self commutated six pulse converters operating at fundamental frequency, in which case the harmonic orders are the same as for thyristor converters, or operating at low frequencies, a few hundred Hz (GTO based).

However, typical self commutated voltage source converters switch at effective frequencies above 1 kHz (above

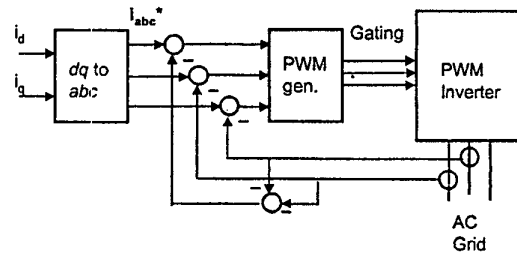

Fig. 6. Current regulated PWM inverter. (Real power component: i_d , reactive power component: i_q).

the 17th harmonic) and do not introduce significant low frequency harmonics. They can therefore be viewed as supplying clean power. This assumes that the ac grid does not have resonant frequencies at one of the inverter harmonic frequencies.

Although the voltage produced may be sinusoidal under steady state conditions, there may be transients resulting in flicker with some types of distributed generation, particularly wind and photovoltaic energy systems. This is the result of varying output power. The effect on the voltage at the point of connection will depend upon the strength of the ac grid to which the DG is connected and the speed of response of its voltage regulator. In addition, the control of the DG must take into account the possible voltage unbalance of the ac grid.

In addition, distributed generation equipped with a PWM inverter interface can be used to alleviate power quality problems present on the ac grid. The requirement is to have independent control over the real and reactive components of the power injected into the ac grid. Under these conditions, the distributed generator can be configured to behave as one or more of the following active power conditioners or compensators, including:

- (a) Static var compensator (STATCOM) functions: reactive power is injected into the ac grid to regulate the voltage at the point of coupling, reactive power can be controlled to regulate the total plant power factor, reactive power can be used to mitigate voltage flicker. The STATCOM function can also be used to mitigate voltage sags. However, sag mitigation using a shunt device requires a significant amount of reactive current and the voltage support capacity at the point of common coupling (PCC) depends upon the reactance of the line and transformer (if present). The rating of the inverter may have to be significantly increased. Voltage support at points upstream from the PCC is even more problematic. Typically, the inverter would be disconnected from the ac grid, when this voltage drops below a critical value. Reconnection requires resynchronization.
- (b) Dynamic voltage restorer (DVR) functions: a series winding, associated with an inverter fed from the dc bus, can be included in the installation to inject the voltages required to support the ac grid voltage at the point of coupling during voltage sags and swells [6]. These are mostly the result of single-phase faults on adjacent feeders.

Implementing DVR functions may result in unbalanced currents and require a redesign of the dc capacitor.

- (c) Active power filter functions: harmonic current loops can be added to the interface inverter so that harmonic current components in phase opposition to the harmonics produced by the loads are injected into the system [7]. These current components cancel the load harmonics and the current drawn from the ac grid is sinusoidal. In order to implement this function however, changes may have to be made to the power circuit. In particular, the dc bus voltage may have to be increased.

It should be noted that functions (a) and (c) and to a certain extent (b) do not require real power. The generation scheme can therefore provide these services even in the absence of real power, for example in the absence of wind. Also, in most operations as power quality compensator, the inverter may have to function above the rating required for generation alone.

It could be argued that the effect of distributed generation might be limited by the presence of the coupling transformer. This is not necessarily true of the schemes described above, since the voltage source inverter must be coupled to the ac grid through a reactance. The transformer leakage reactance usually provides the necessary coupling reactance, so that no additional reactor may be needed. In addition, the effect of distributed generation on power quality will usually be limited to the bus to which the system is connected.

V. CONCLUSIONS

This paper has demonstrated the potential of distributed generation systems equipped with an appropriate power electronic interface to perform functions other than the supply of real power to the grid. These additional functions however require the use of dc/ac self commutated PWM inverter interfaces, such as are found in the newer distributed generation systems. The functions that can be performed include those of conventional synchronous generators such as reactive power compensation. In addition, the speed of response of electronic interfaces is faster than that of conventional synchronous and induction generators. The systems can therefore be equipped with the control features found in STATCOMs, namely voltage regulation and flicker control, as well as active power filtering and harmonic cancellation. Finally, either in the STATCOM or DVR configurations, the DG can compensate for voltage sags resulting from faults on the power system. In general, kVA rating of the inverter may have to be increased to carry out these added functions.

VI. ACKNOWLEDGEMENTS

The authors wish to acknowledge the support of the Natural Sciences and Research Council (NSERC) of Canada for support of this work.

VII. REFERENCES

- [1] M.R. Patel, *Wind and Solar Power Systems*, CRC Press, 1999.

- [2] S. Bhowmik, R. Spee, J.H.R. Enslin, 'Performance Optimization for Doubly Fed Wind Power Generation Systems', in *IEEE Trans. Ind. Applications*, Vol. 35, No. 4, pp.949-958, 1999.
- [3] J.F. Childs, 'The Role of Converters and their Control in the Recovery of Wave and Wind Energy', in *IEE Conf on Power Elect. And Variable Speed Drives*, pp. 179-184, London, Sept. 1996.
- [4] J.J. Bxura, 'Photovoltaic Research and Demonstration Activities at New England Electric', in *IEEE Trans. On Energy Conversion*, Vol. 10. No. 1, pp.169-174, March 1995.
- [5] J.H.R. Enslin, M.S. Wolf, D.B. Snyman, W. Swiegers, 'Integrated Photovoltaic Maximum Power Point Tracking Converter', in *IEEE Trans. Ind. Electronics*, Vol. 44, No. 6, pp.769-773, 1995.
- [6] K. Haddad and G. Joos, 'Distribution System Voltage Regulation Under Fault Conditions Using Static Series Regulators', in *IEEE Ind. Appl. IAS'97 Conf. Rec.*, New Orleans, Oct. 1997.
- [7] T. Thomas, K. Haddad, G. Joos and A. Jaafari, 'Performance Evaluation of Three and Four Wire Active Filters', in *IEEE Ind. Appl. IAS'96 Conf. Rec.*, pp. 1016-1023, San Diego, Oct. 1996.

VIII. BIOGRAPHIES

Geza Joos (SM) received the M.Eng. and Ph.D. degrees from McGill University, Montreal, Canada in 1974 and 1987, respectively. From 1975 to 1978, he was with Brown Boveri and from 1978 to 1988 with the Ecole de technologie superieure, Universite du Quebec. Since 1988, he has been with the Department of Electrical and Computer Engineering at Concordia University, Montreal. His research interests are in power converters, with applications to FACTS and Custom Power Devices and electrical drives.

Boon-Teck Ooi (SM) received the B.Eng. Hons. Degree from the University of Adelaide, Australia, the S.M. degree from the Massachusetts Institute of Technology, Cambridge, and the Ph.D. degree from McGill University, Canada, in 1962, 1967, and 1970, respectively. He is presently a Professor with the Department of Electrical and Computer Engineering, McGill University. His research interests are in the areas of linear induction motors, electrodynamic magnetic levitation with superconducting magnets, subsynchronous resonance phenomena, stability of long-distance power transmission, HVDC and power electronics.

Donald T. McGillis received the B.Sc. degree from Loyola College, Montreal, Canada, and the B.Eng. degree from McGill University, Montreal, Canada, in 1949 and 1951, respectively. Since 1951, he was with Hydro-Quebec as the Head of the Analytical Division, Manager of System Engineering and Advisor to the Vice-President, System Planning. As a member of Canadian Electrical Association, he served as Chairman of the Engineering R & D Operating Division, Consultative Committee on Outage Systems where he is presently active. He is an Adjunct Professor at Concordia University and at McGill University.

Francisco D. Galiana (F) received the B.Eng. Hons. degree from McGill University, Montreal, Canada, and the S.M. and Ph.D. degrees from the Massachusetts Institute of Technology, in 1966, 1968 and 1971, respectively. He spent a few years at the Brown Boveri Research Center and the University of Michigan. Since 1977, he has been a Professor with the department of Electrical Engineering, McGill University. His research interests are in the areas of power system operation and planning including expert systems applications, load flow and optimal load flow analysis, system restoration, power system computer simulation environments, load forecasting and management, symbolic computation, unit commitment and hydro-thermal scheduling.

Richard J. Marceau (M) obtained his B.Eng. (1977) at McGill University, his M.Sc.A. (1983) at Ecole Polytechnique de Montreal and his Ph.D. at McGill in 1993. From 1978 to 1982, he worked for MONENCO in system planning, relaying and power station design. He also worked at Hydro-Quebec from 1982 to 1990. He is currently an Associate Professor at Ecole Polytechnique de Montreal where his immediate research interests include dynamic security analysis, "faster than real-time" computing and virtual reality operator training systems.